

JAN GARNCAREK DESIGN

tel. +48 600-441-308 / e-mail: jangarncarekdesign@gmail.com
pl. Konfederacji 56, 01-834 Warsaw, Poland / NIP: PL1181947234



name: CBS-2

category: table

composition: brass, steel, concrete

reference: The concrete table legs are architectural elements from the designer's family home, which were dismantled during the renovation of the historic building. The designer approaches the original pre-war fabric of the places he grew up in with great sentiment. Often giving it a new function and meaning. In this way, the old world does not pass away, but in fact acquires greater

significance. Limited edition of 2 pieces.

production: handcrafted

dimensions:

200 cm width x 100 cm depth x 73 cm height

79 in width x 40 cm depth x 29 cm height

(tolerance: 0,5 cm / 0,2 in)

weight: 320 kg / 705 lb

price: 25700 euro / 29500 usd

lead time: 8-10 weeks

payment terms: deposit 50 % upon order,
balance prior to shipping

customization: available

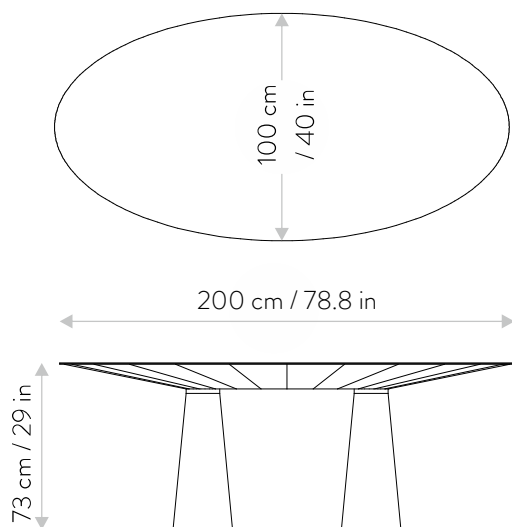

packing: crate on europallet

220 cm x 120 cm x 90 cm,

total weight 380 kg

87 in x 47 in x 35.5 in,

total weight 840 lb

packet contains: certificate, instructions,
gloves, polishing sponge

attention: product made of pure brass. The material naturally tarnishes. Touching brass parts without gloves may result in finger marks. More information in our brochure "brass conservation".

