

JAN GARNCAREK DESIGN

tel. +48 600-441-308 / e-mail: jangarncarekdesign@gmail.com
pl. Konfederacji 56, 01-834 Warsaw, Poland / NIP: PL1181947234



name: Metropolis

category: table lamp

type: 201602

composition: brass (waxed)

reference: Lamp created as a result of fascination with the possibilities offered by the metallurgy. The lamp exposes what is most beautiful in brass. Here I see the beauty in two different forms. The first are various types of dishes or shields. Their phenomenon is the occurrence of irresolvable forms. The flat sheet is flaccid and prone to deformation. Only after its extrusion and giving its sphericity, it gains its constitutionality. The second form are the heavy machine parts, simple and perfectly matched "geometries". Metropolis is a clash of both of these fascinations. The lamp is made by hand with a full brass, using traditional methods of metalworking, as well as other methods, slowly

fading into obscurity. An example of which are the plates executed by metal spinning method.

production: handcrafted

dimensions:

52 cm width x 81 cm height x 25 cm depth
20,5 in width x 32 in height x 10 in depth
(tolerance: 0,5cm / 0,2in)

weight: 15 kg / 33 lb

voltage: 120V, 240V

lamping: 1 x E27 dimmable, 60W, 50-60
H z

lumens: 800 lm

color temperature: 3000 K

tightness class: IP 21

certificates: CE approved, RoHS

price: 9100 euro / 9560 usd

lead time: 8-10 weeks

payment terms: deposit 50 % upon order,
balance prior to shipping

customization: available

dimensions:

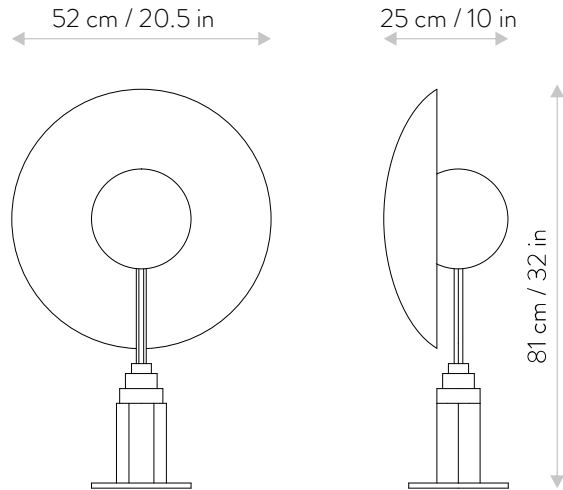

wire pass options:

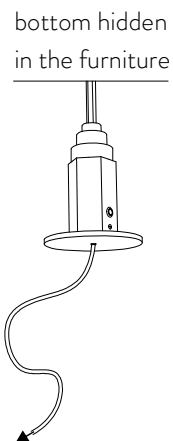
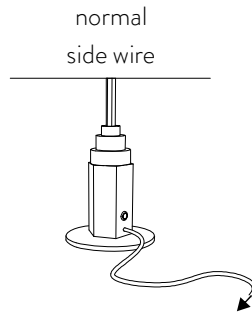

packing: 2 wooden boxes:

74 cm x 33 cm x 33 cm and 58 cm x 58 cm x 15 cm, total weight 20 kg

29 in x 13 in x 13 in and 23 in x 23 in x 6 in, total weight 44 lb

packet contains: certificate, instructions, gloves, polishing sponge, bulb

attention: product made of pure brass. The material naturally tarnishes. Touching brass parts without gloves may result in finger marks. More information in our brochure "brass conservation".

