

# JAN GARNCAREK DESIGN

tel. +48 600-441-308 / e-mail: jangarncarekdesign@gmail.com  
pl. Konfederacji 56, 01-834 Warsaw, Poland / NIP: PL1181947234



**name:** Kometa

**distribution:** Studio Fenice

**category:** pendant lamp / floor lamp

**type:** Sf202203

**composition:** brass, glowing glass

**reference:** Pendant lamp of oblong form.

The bottom part consists of semispherical brass with a point of light, the upper one resembles a light footprint conjured by the brass sphere. The lamp was inspired by icons located in the Museum in Supraśl, mostly with works of Nowosielski. The iconography depicts esoteric themes in a synthetic, almost graphical way. The designer's reflection on religion was never limited by Christian dogma. The unfulfilled need of understanding has always sparked the designer's imagination who places his spirituality in the awe of celestial bodies. He often watches the night sky. The lamp is a trial to materialize the impressions by giving

them a simplified visual form. The main inspiration was a comet, also due to its religious symbolism. It is an omen of new beginning, first and foremost hope.

**production:** handcrafted

**dimensions:** 20 cm / 8 in width x ixture height to order min. 112 cm / 44 in height x 31 cm / 12 in depth (tolerance: 0,5 cm / 0,2 in)

**weight:** 10 kg / 22 lb

**voltage:** 120V, 240V

**lamping:** 5x LED 12V DC (power supply 110-240V in additional)

**LED life:** 50 000 h

**tightness class:** IP 21

**certificates:** CE approved, RoHS

**lead time:** 13 weeks

**payment terms:** deposit 50 % upon order, balance prior to shipping

**customization:** available

**finished:** - brass, copper, nickel, black painted  
- glass

**dimensions:**

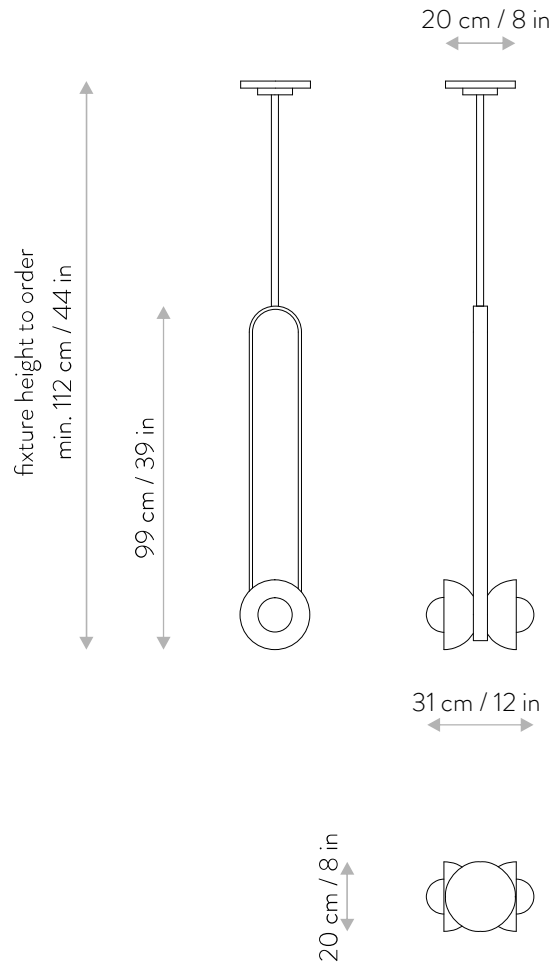

**packing:** 1 wooden box :  
30 cm x 40 cm x 120 cm, total weight 30 kg  
12 in x 16 in x 47 in, total weight 66 lb

**packet contains:** certificate, instructions,  
gloves, polishing sponge, mounting pins

**attention:** product made of pure brass.  
The material naturally tarnishes. Touching  
brass parts without gloves may result in  
finger marks. More information in our  
brochure "brass conservation".





