

JAN GARNCAREK DESIGN

tel. +48 600-441-308 / e-mail: jangarncarekdesign@gmail.com
pl. Konfederacji 56, 01-834 Warsaw, Poland / NIP: PL1181947234



name: Baba

distribution: Studio Fenice

category: sconce

type: Sf202203

composition: travertine / brass

reference: Stone sconce, kind of amulet. The first lamp the designer made only in stone. Solid, elongated body resembles human head. The nature always sparked the folk's imagination. Every culture was full of myths. Contemporarily we live in a derivative environment, constructed entirely by human. Sometimes we lack the ingredient of nature, which except its dangerous character surrounded people with care. In Slavic mythology pebbles found in the field were believed to hold extraordinary power. The earth that is constantly in movement pushes even big stones out. For peasants working in the field the occurrence of a stone was almost a mystical event.

They believed that pebbles were gods, they cared for them and presented them sacrifices. It was supposed to nourish the ground and ensure good harvest. They were called "Stone babas".

customization: available

production: handcrafted

dimensions: 10 cm / 4 in width x 48 cm / 19 in height x 17 cm / 9 cm / 3,5 in (tolerance: 0,5 cm / 0,2 in)

weight: 3 kg / 7 lb

voltage: 120V, 240V

lamping: LED 12V DC (power supply 110-240V in additional)

LED life: 50 000 h

tightness class: IP 21

certificates: CE approved, RoHS

price: 3 820 euro / 4 200 usd

lead time: 12 weeks

payment terms: deposit 50 % upon order, balance prior to shipping

dimensions:

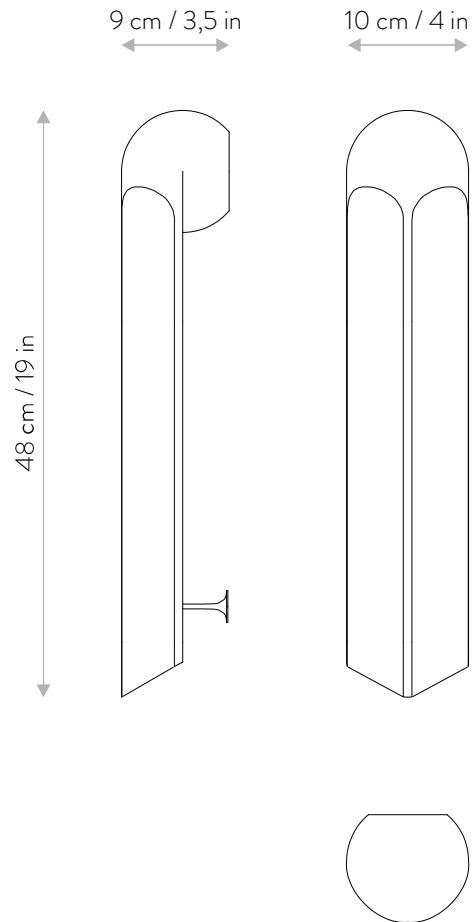

packing: 1 wooden boxes:

22 cm x 60 cm x 22 cm, total weight 12 kg

9 in x 24 in x 9 in, total weight 7.5 lb

packet contains: certificate, instructions, gloves, mounting pins

attention: product made of pure brass. The material naturally tarnishes. Touching brass parts without gloves may result in finger marks. More information in our brochure "brass conservation".

